



Industrial Range

MODEL

**580DX**

DUAL RANGE TESTER



Hydraulic  
Dead-Weight  
Testers.

Primary standards  
for Pressure  
Calibration

- ▶ Range from 1 - 700 bar
- ▶ Supplied with software

- ▶ Standard Accuracy to 0.015%
- ▶ Class 'A' Accuracy to 0.006%



DH·Budenberg  
The Pressure Reference

# Industrial Range

MODEL

# 580DX DUAL RANGE TESTER

Hydraulic  
Dead-Weight  
Testers.

Primary standards  
for Pressure  
Calibration

Standard Accuracy to 0.015%  
Class A with UKAS  
Calibration Certificate 0.006%

#### RANGES:

700 bar 10000 lb/in<sup>2</sup>  
70000 kPa 700 kg/cm<sup>2</sup>

## ACCURACY

All certificates issued for DH-Budenberg Dead-weight Testers are fully traceable to national standards via equipment with UKAS calibration certificates. A standard accuracy of 0.015% is achieved from 10% of range using software supplied to compensate for the effects of gravity, temperature and the actual area of piston unit. Standard accuracy without any corrections for actual area is 0.02% from 6 to 700 bar, 0.025% from 1 to 6 bar. Higher accuracy Class 'A' testers are available (supplied with UKAS Calibration certificates for area and mass) allowing an accuracy of 0.006% to be achieved.

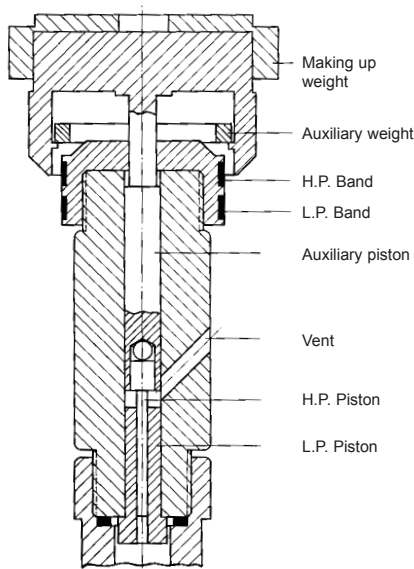

## 580 SERIES BASE

The 580 series base can be used with any of the 580 series pistons to give ranges 1 - 120 bar with a 580L, 2 - 300 bar with a 580M, 1 - 700 bar with a 580DX, and 1 - 1200 with a 580HX.

All units are top loading for ease of use and weight sets are fully interchangeable. This means that weight sets in alternative pressures are readily available and customers with more than one 580 series tester can interchange weight sets between tester of the same range.

The base features a dual area screwpress which allows low pressure priming and high pressure control. The 580DX is a dual area piston / cylinder unit with 1/8in<sup>2</sup> and 1/80in<sup>2</sup> areas. Changing between ranges is fully automated meaning that users have an extremely flexible instrument covering the range with one piston / cylinder assembly and one weight set. The low pressure piston / high pressure cylinder is tungsten carbide, other parts are fully hardened and stabilised tool steel.

Please note: Due to DH-Budenberg's policy of continuous improvements, specifications may be subject to change without notice.

## WEIGHTS SUPPLIED

bar or kg/cm <sup>2</sup>	kPa	lb/in <sup>2</sup>
Low range 1-60	Low range 100-6000	Low range 10-800
High range 10-700	High range 1000-70000	High range 100-10000
Piston 1 or 10 1 wt 9 or 90 5 wts 10 or 100 1 wt 5 or 50 2 wts 2 or 20 1 wt 1 or 10 1 wt 0.5 or 5	Piston 100 or 1000 1 wt 900 or 9000 5 wts 1000 or 10000 1wt 500 or 5000 2 wts 200 or 2000 1wt 100 or 1000 1wt 50 or 500	Piston 10 or 100 1 wt 90 or 900 8 wts 100 or 1000 1 wt 50 or 500 2 wts 20 or 200 1 wt 10 or 100 1 wt 5 or 50
Optional fine increment weights 2 wts 0.2 or 2 1 wt 0.1 or 1 1 wt 0.05 or 0.5 2 wts 0.02 or 0.2 1 wt 0.01 or 0.1	2 wts 20 or 200 1wt 10 or 100 1wt 5 or 50 2 wts 2 or 20 1wt 1 or 10	2 wts 2 or 20 1 wt 1 or 10 1 wt 0.5 or 5 2 wts 0.2 or 2 1 wt 0.1 or 1

## SOFTWARE

For maximum ease of use, computer software is supplied with all units. There are two software packages, one for standard accuracy, one for Class 'A'. The software allows the users to correct for the effects of environmental factors such as gravity and temperature and to determine the precise pressure generated by the Dead-weight testers.

## ACCESSORIES

There are many accessories which can be supplied for use with the Dead-weight testers. These include liquid / liquid seals, two gauge stands, power rotation unit and many others. DH-Budenberg have extensive experience in the use of Dead-weight testers and can supply accessories for many applications. A separate data sheet of accessories is available.

## PACKING DETAILS

1 carton containing base, tool roll and piston unit:  
59 x 49 x 38cm. 0.110m<sup>3</sup>, Nett 20kg, Gross 22kg.  
1 carton containing weights:  
32 x 32 x 38cm. 0.04m<sup>3</sup>, Nett 60kg, Gross 64kg.

## SPARES, REPAIR AND RE-CERTIFICATION

Comprehensive service and Calibration capability of both DH-Budenberg and non DH-Budenberg test equipment:

Dead-weight Testers (working service or full overhaul).

Gauges (all types, all manufacturers).

Portable calibrators (DH-Budenberg & non-DH-Budenberg).

Comparators.

All accuracy ranges can be supplied with UKAS Calibration Certificates.

Certification traceable to national standards.

Rapid turn-around times and hire items available as a temporary replacement for strategically important plant.

**For further information on Accessories, and other product information contact DH-Budenberg and ask for a Data sheet.**



#### Calibration Dynamics Ltd

7 Regents Court  
South Way  
Walworth Industrial Estate  
Andover  
Hampshire SP10 5NX

#### TELEPHONE

+44 (0) 1264 339030

#### FAX

+44 (0) 1264 339040

#### WEBSITE

<http://www.calibrationdynamics.com>

#### EMAIL

[sales@calibrationdynamics.com](mailto:sales@calibrationdynamics.com)