

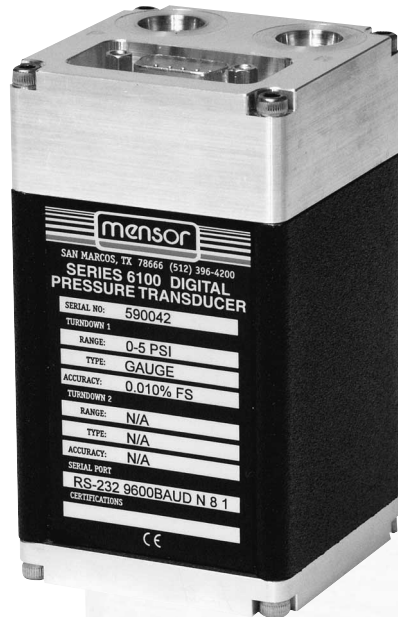

Digital Pressure Transducer Series 6100



Features

- 0.010% FS Accuracy
- Full Scale Ranges from 0 – 0.36 psi up to 0 – 6000 psi
- Resolution to 1 ppm
- Absolute or Gauge
- Pneumatic or Hydraulic
- RS-232 or RS-485 Communication
- Remote Operation to 4000 Feet
- Multi-drop Capability
- Fast Response (20ms)
- CE Compliant

With a precision to 0.003% FS and an accuracy to 0.010% FS, the Series 6100 Digital Pressure Transducer provides exceptional performance.

The Mensor Series 6100 is a high-accuracy pressure transducer that combines high performance and cost effectiveness for OEM and test system applications. RS-232 or RS-485 allows the 6100 to communicate with any MS-DOS compatible computer over the serial port. A nine pin, D-sub connector is provided to simplify the connections to the serial port of the system or host computer.

Proprietary characterization techniques help the 6100 achieve an accuracy of 0.010% FS and a precision of 0.003% FS over the operating temperature range. Every 6100 is temperature compensated from 15 to 45°C to insure a high level of performance at varying temperatures. The accuracy statement includes linearity, hysteresis,

repeatability and temperature errors over the operating range.

The lowest FS psig pressure range is 0.36 psig, while the lowest FS absolute range is 5 psia. Zero and span can be adjusted via the serial interface. There are no other adjustments required by the end user.

Options

- Analog Output
- Secondary Calibration Range
- Relief Valves
- Altitude output in feet or meters

Series 6100

Digital Pressure Transducer Specific Data Series 6100

General Specifications

Accuracy 0.010% FS
Precision 0.003% FS
Calibration Stability after warm-up
Better than 0.010% FS for 180 days.
Zero and Span may be reset via the serial interface without affecting Linearity.

Calibration

Cal Interval: 180 Days
Uncertainties: 0.010% FS
Adjustments: Zero and Span via the serial interface

Pressure Ranges Standard

psia: 0 – 5 to 0 – 6000 max
psig: 0 – 0.36 to 0 – 6000 max

Pressure Range Bidirectional, Vacuum

psig: -0.36 to +0.36 min, -atm to 6000 max

Pressure Units Available

psi, inHg @ 0°C and 60°F, inH₂O @ 4°C, 20°C and 60°F, ftH₂O @ 4°C, 20°C and 60°F, mTorr, inSW @ 0°C, ftSW @ 0°C, ATM, bars, mbars, mmH₂O @ 4°C, cm H₂O @ 4°C, MH₂O @ 4°C, mmHg @ 0°C, cmHg @ 0°C, Torr, hPa, mPa, kPa, Pa, D/cmsq, g/cmsq, kg/cmsq, mSW @ 0°C, OSI, PSF, TSF, TSI, μHg @ 0°C, %fs.
All seawater units are 3.5% salinity.

Resolution

Up to 1 ppm, depending on measurement units and range

Overpressure Limit Storage 150% FS or greater, depending on range
0 to 70°C

Warm-up 10 minutes to rated accuracy

Reading Rate 50 per second

Response Time >20ms

Orientation Effects FS ranges less than 30 psi, specify orientation

Communications RS-232 or RS-485. From 9600 to 56k baud.

Case Size see "Dimensions"

Weight Less than 1 lb. (.45 kg.)

Media Compatibility Clean, dry, non-corrosive gases for ranges <15 psi. All other ranges compatible with aluminum, 316 stainless steel, brass, Buna N, Viton, sealant and silicone grease. Not designed for oxygen use.

Fittings

Female 7/16-20 SAE/MS straight thread port. 1/8 inch female NPT adapter fitting is included.

Power

6-20 VDC, 55 mA @ 12 VDC

Mechanical Shock 3g max

Multi-drop Capacity The maximum number of RS-485 Series 6100 transducers which can be connected to a single host computer is 31.

Compliance

The Series 6100 is compliant to the following CE Standards: EN 50081-1, EN 50082-1, EN 50081-2, and EN 50082-2.

Options

Analog Output: 0-1, 0-5 and 0-10 VDC @ 0.010% FS accuracy.

Relief Valves

Altitude output in Feet or Meters

Dimensions

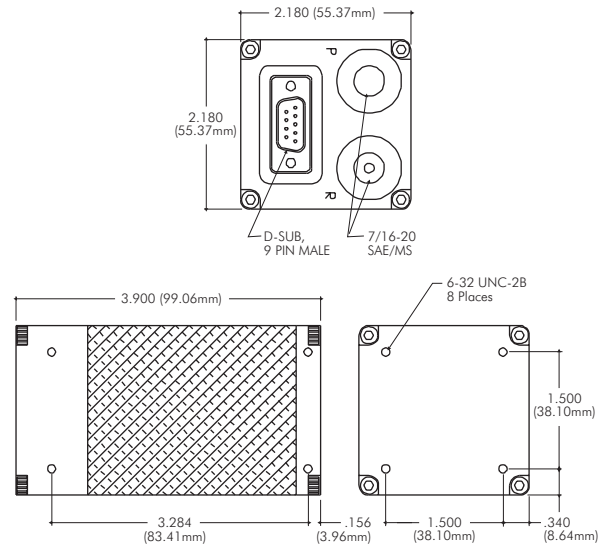

Accuracy includes the following uncertainties in the pressure reading: repeatability, pressure hysteresis, creep, linearity, and temperature effects over the compensated range.

Precision is the closeness of agreement between independent test results obtained under stipulated conditions.

Per ANSI/NC SL Z540-2-1997 (U.S Guide to the Expression of Uncertainty in Measurement) that "the term precision should not be used for accuracy".

These models are calibrated with primary standards traceable to N.I.S.T. The Mensor Calibration Laboratory is accredited to ANSI/NC SL Z540-1-1994 and ISO/IEC 17025-1999 by A2LA.

For more details on calibration of Mensor products see Technical Note entitled "Accuracy Specifications for Mensor Products" (available on our web site www.mensor.com).

Since product improvement is a continuous process at Mensor, we reserve the right to change specifications without notice.

Represented by:

Mensor Corporation

201 Barnes Drive, San Marcos, Texas 78666

Phone: 512.396.4200 Toll free: 800.984.4200 Fax: 512.396.1820

Web site: www.mensor.com E-mail: sales@mensor.com



CDS6100E